

Single & three-phase power distribution cores



Single & three-phase power distribution cores

Wiltan single and three-phase strip wound distribution transformer cores are operating in many thousands of transformers in the UK and overseas.

Advantages

The cores are strip wound in grain oriented silicon iron and offer the following advantages when compared with stack laminated cores: -

1. Reduction in iron losses – lower stand-by losses.
2. Reduced assembly time
3. Ease of storage and handling.

Range

No standard range of design exists owing to the diversity of design requirements but we detail in this Section a range of standard core limb sections suitable for use with Bobbins ranging from 2.5/8" to 7.1/8" inside diameter. These sections can be produced with any desired window so that great flexibility in design is possible and advantage should be taken of these standard sections whenever practicable because tooling already exists and shorter delivery times can therefore be offered.

Cores of this type can be produced in the cut or uncut form, single or three-phase, up to one tonne.

Cross Section

Distribution transformer cores can be supplied with the following cross sections:

- a) **Cruciform Section:** - This gives a simulated circle to accommodate ease of winding with heavy strip copper. (Figs 1&1a)
- b) **Half Cruciform Section:** - In shell type construction, a full cruciform section is obtained on the centre limb when 2 loops are used. (Fig 2)
- c) **Rectangular Section:** - (Fig 3)

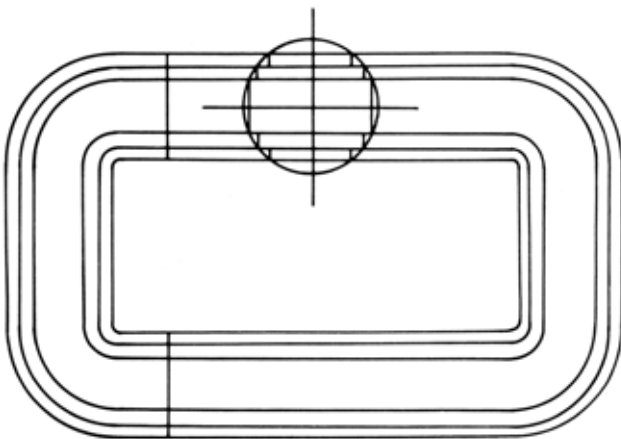

Fig. 1

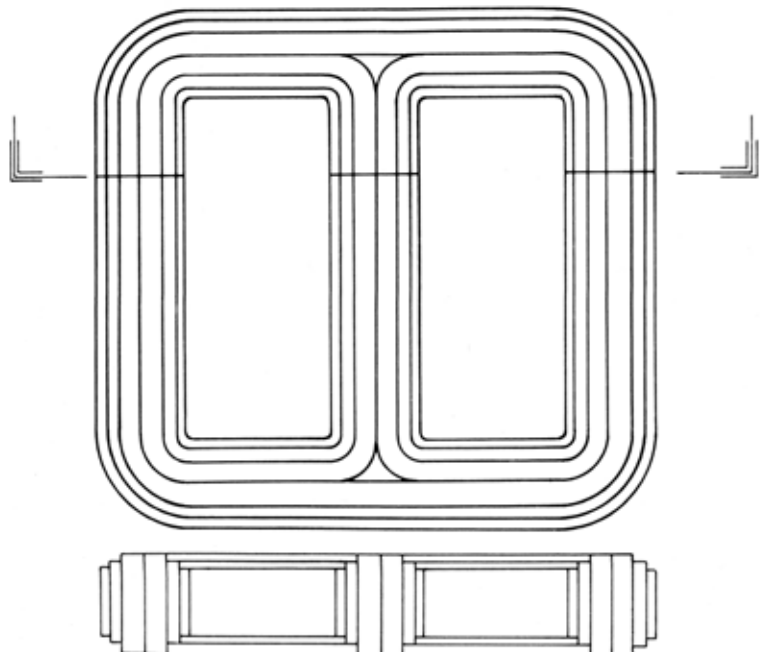

Fig. 1a

STANDARD CORE CIRCLE DIAMETERS FOR SINGLE & THREE-PHASE POWER DISTRIBUTION CORES

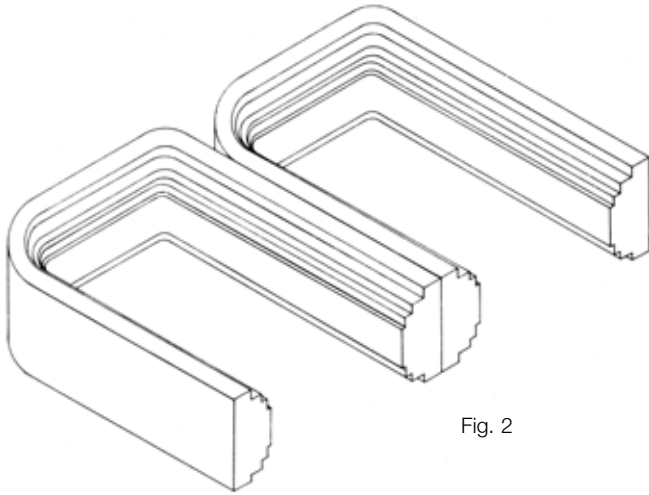

Fig. 2

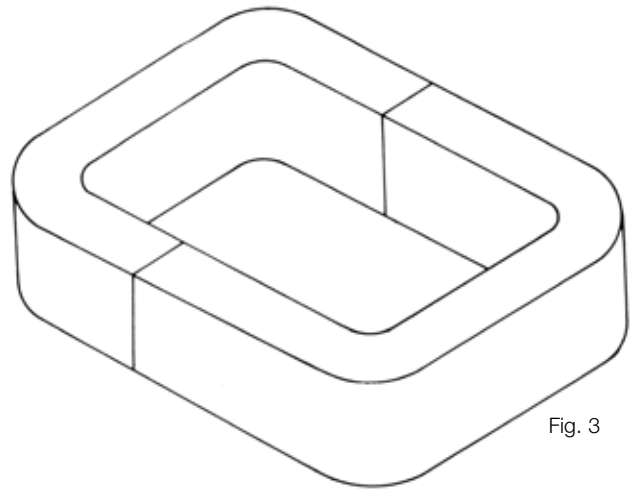

Fig. 3

Core Section Ref	Nominal Core Circle Diam. (ins.)	No. of Steps	Nett Cross Section of Iron (cm ²)	% of Core Circle Area
2 ½ SD	2 ½	3	25.55	85
2 ¾ SD	2 ¾	3	30.97	85
3 SD	3	4	38.39	88
3 ¼ SD	3 ¼	4	44.90	88
3 ½ SD	3 ½	4	51.75	87
3 ¾ SD	3 ¾	5	61.10	90
4 SD	4	5	69.68	90
4 ¼ SD	4 ¼	5	78.71	90
4 ½ SD	4 ½	5	88.39	90
4 ¾ SD	4 ¾	5	97.43	89
5 SD	5	5	108.97	90
5 ¼ SD	5 ¼	7	123.36	93
5 ½ SD	5 ½	7	135.43	93
5 ¾ SD	5 ¾	7	148.33	93
6 SD	6	7	160.27	93
6 ¼ SD	6 ¼	7	174.85	93
6 ½ SD	6 ½	7	189.00	93
6 ¾ SD	6 ¾	7	203.17	93
7 SD	7	7	219.00	93

EXAMPLES OF CUT SINGLE PHASE CRUCIFORM CORES

Core Reference	D 5000	D 15000	D 25000
Approx. k Va Rating	5	15	25
Window Size	7 ¾" x 3 ¾"	11" x 4 ¾"	11 ⅝" x 4 ⅝"
Overall Size	12 2½/32" x 8 2½/32"	17" x 10 ⅝"	18 1¼/16" x 11 1¼/16"
Mean Length of Flux Path	77.47 cms	101.16 cms	108.9 cms
Core Section Reference	2 ¾ SD	3 ¼ SD	3 ¾ SD
Minimum Inside Dimensions of Bobbin	2 ⅞"	3 ⅞"	3 ⅞"
Nett Cross Section of Iron	30.97 cms.	44.91 cms.	61.1 cms.
Estimated Finished Weight (Min.)	18.371 kgs.	34.70 kgs.	50.576 kgs
Maximum Total Loss, At guarantee level of 1.5 Tesla, 50 Hz.	25.9 watts	48.9 watts	71.3 watts

Magnetic Characteristics and Guarantees

All cores are individually inspected for physical and electrical characteristics and conform to the following guarantees: -

SINGLE PHASE

Uncut Cores

Test Level 1.5 Tesla, 50 Hz.

Total Iron Loss not greater than 1.41 Watts/kg.

Total R.M.S. Magnetising VA not greater than 3.1 VA/Kg.

Cut Cores

Test Level 1.5 Tesla, 50 Hz.

Total Iron Loss not greater than 1.41 Watts/Kg.

Total R.M.S. Magnetising VA not greater than $3.1 + \frac{179}{L_m}$ VA/kg.

THREE PHASE

Uncut Cores

Test Level 1.5 Tesla, 50 Hz.

Total Iron Loss not greater than 1.6 Watts/Kg.

Total R.M.S. Magnetising VA not greater than 3.9 VA/Kg.

Cut Cores

Test Level 1.5 Tesla, 50 Hz.

Total Iron Loss not greater than 1.6 Watts/Kg.

Total R.M.S. Magnetising VA not greater than $3.9 + \frac{2.05 \times \text{AREA}}{\text{Weight}}$ Va/kg.

Where AREA is the nett cross sectional area in cms² and WEIGHT is in kilos.

Information Required

When enquiring or ordering power distribution transformer cores, the following information is required: -

Window Dimensions

Strip Width or core section reference

Build Up

Electrical Specification, if differing from standard guarantees